

YQZ800



DESCRIPTION

Kingtec YQZ800 units are designed for fresh and frozen applications on the 15~40m³ medium refrigerator trucks and vans. Integrative structure is easy to install, super-thin evaporator design compared to the traditional product goods loaded more. The road compressor is powered by the vehicle engine.

SYSTEM COMPONENTS

- Integrated condenser and evaporator assembly
- Road compressor (With magnetic clutch)
- In cab control box and wiring harness

REFRIGERENT (CHLORINE ZERO)

- YQZ800 (R404A): HFC R404A 3.0kg

ROAD COMPRESSOR

- YQZ800 compressor : QP31 (313cc);
- Max recommend RPM: 3000rpm

AIRFLOW VOLUME

- YQZ800 Evaporator : 4012m³/h (2360 cu ft/min)

DEFROST

- Automatic hot gas defrost

WEIGHTS

- YQZ800 Integrated condenser and evaporator: 175kg

Refrigeration capacity
conditions @ 30°C(86°F) ambient
Road compressor 2400rpm
ATP standard



Conditions @ 38°C(100°F) ambient
Road compressor 2400rpm
National-standard



YQZ800 (R404A)			YQZ800 (R404A)		
Air return/on the road	Watts	BTU/hr	Air return/on the road	Watts	BTU/hr
0°C (32°F)	7200	24558	2°C (35°F)	6800	19790
-20°C (-4°F)	4100	13985	-18°C (0°F)	3800	11765

YQZ800 DIMENSION : mm(in)

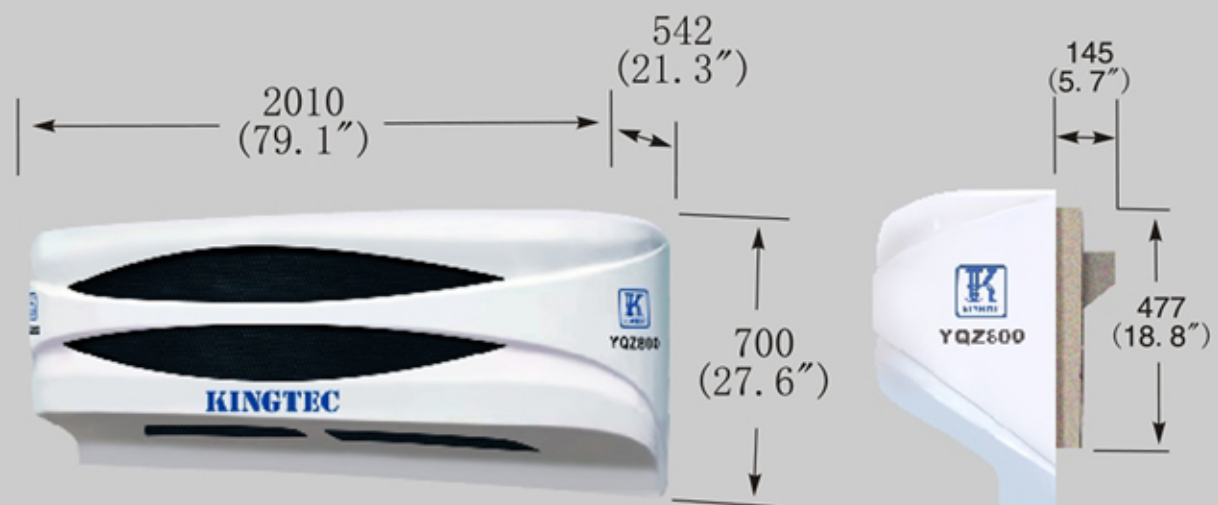

YQZ800 Integrated condenser and evaporator



LAE controller

WARRANTY SUMMARY

Specific terms of the Kingtec express warranty are available on request. Further, Kingtec excludes liability in contract and tort (including strict liability and negligence) for any special, indirect or consequential damages by reason of the installation or use of any covered product or its mechanical failure.



YQZ800E



DESCRIPTION

Kingtec YQZ800E units are designed for fresh and frozen applications on the 15~40m³ medium refrigerator trucks and vans. Integrative structure is easy to install, super-thin evaporator design compared to the traditional product goods loaded more. The road compressor is powered by the vehicle engine and while a second compressor is powered by an electric motor, making it possible to use electric standby to drive the unit. The stand-by unit is installed on the on the skirt of the truck or vans.

SYSTEM COMPONENTS

- Integrated condenser and evaporator assembly
- Road compressor (With magnetic clutch)
- Electric stand-by assembly
- In cab control box and wiring harness

REFRIGERENT (CHLORINE ZERO)

- YQZ800E (R404A): HFC R404A 3.0kg

ROAD COMPRESSOR

- YQZ800E compressor : QP31 (313cc);
- Max recommend RPM: 3000rpm

AIRFLOW VOLUME

- YQZ800E Evaporator: 4012m³/h (2360 cu ft/min)

DEFROST

- Automatic hot gas defrost

WEIGHTS

- YQZ800E Integrated condenser and evaporator: 175kg
- YQZ800E Electrical stand-by assembly: 80kg

Refrigeration capacity conditions @ 30°C(86°F) ambient
Road compressor 2400rpm
ATP standard

Conditions @ 38°C(100°F) ambient
Road compressor 2400rpm
National-standard

YQZ800E (R404A)			YQZ800E (R404A)		
Air return/on the road	Watts	BTU/hr	Air return/on the road	Watts	BTU/hr
0°C (32°F)	7200	24558	2°C (35°F)	6800	19790
-20°C (-4°F)	4100	13985	-18°C (0°F)	3800	11765
Electric stand-by 50Hz			Electric stand-by 50Hz		
Air return/on the road	Watts	BTU/hr	Air return/on the road	Watts	BTU/hr
0°C (32°F)	5270	17975	2°C (35°F)	4870	16620
-20°C (-4°F)	3190	10880	-18°C (0°F)	2790	9520

YQZ800E DIMENSION: mm(in)

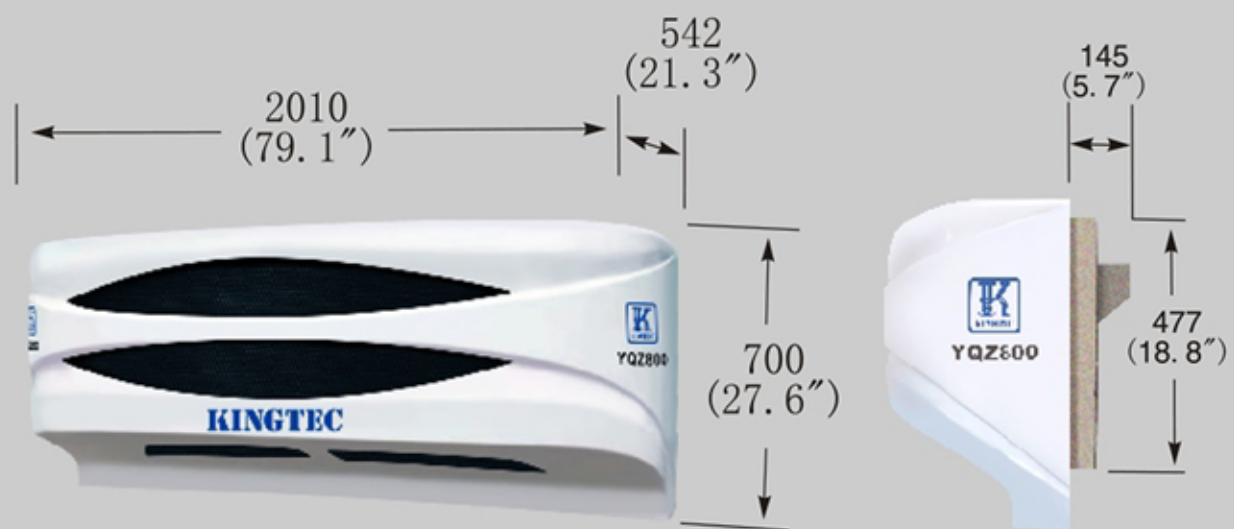

YQZ800E Integrated condenser and evaporator

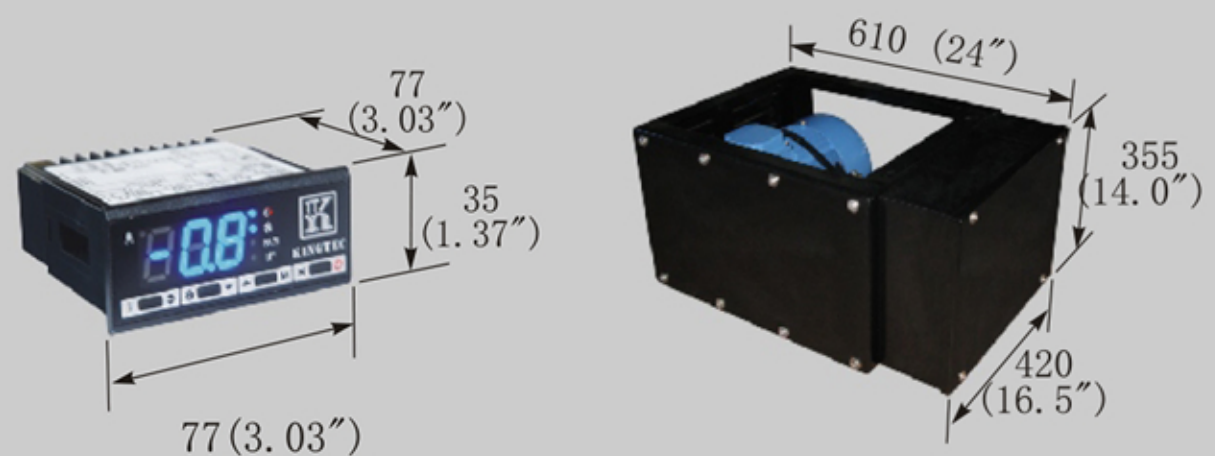

LAE controller

YQZ800E Electrical stand-by assembly

WARRANTY SUMMARY

Specific terms of the Kingtec express warranty are available on request. Further, Kingtec excludes liability in contract and tort (including strict liability and negligence) for any special, indirect or consequential damages by reason of the installation or use of any covered product or its mechanical failure.

